

Bicycle + Stepper Plus

0072032

METAL - Fitness plus



⋮



Due to continuous improvement of technical solutions by Freekids, the presented drawings, including colours and dimensions, may differ slightly from currently manufactured devices.



FreeKids s.c. A. Gąsiorek, Z.Andruszewski
Trzęsowice 32, 55-106 Zawonia

tel./fax: +48 71 312 72 50, +48 724 654 898
e-mail: biuro@freekids.pl www.freekids.pl

rev. 001/2025

Bicycle + Stepper Plus

0072032

METAL - Fitness plus

DEVICE DATA:

Device dimension	1.93 x 0.62 x 1.60 m
Zone dimension	4,93 x 3,65
Fall height	0,85 m
Safety zone area	15,95 m ²
Material	Metal
Compliance with standards	EN 16630

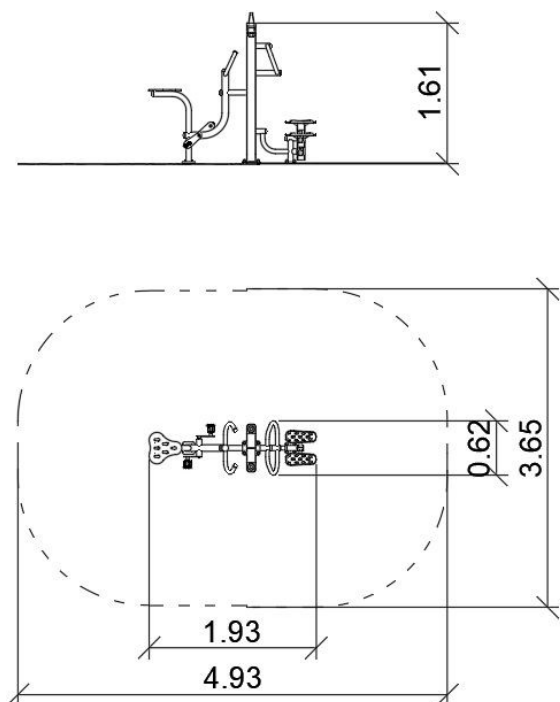

Due to continuous improvement of technical solutions by Freekids, the presented drawings, including colours and dimensions, may differ slightly from currently manufactured devices.



FreeKids s.c. A. Gąsiorek, Z.Andruszewski
Trzęsowice 32, 55-106 Zawonia

tel./fax: +48 71 312 72 50, +48 724 654 898
e-mail: biuro@freekids.pl www.freekids.pl

rev. 001/2025