

Dźwig

0210012

METAL - MINI CITY

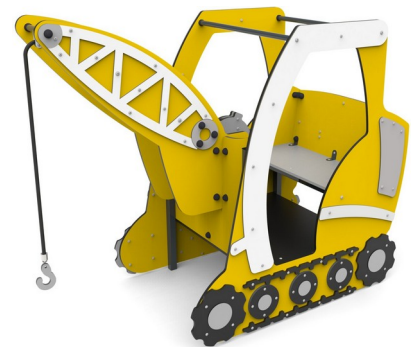

Material specification:

Construction Material	galvanized steel coated with powder paint for durability and corrosion resistance or made of stainless steel
Platforms	HPL Panels
Foundation	buried in the ground to a specified depth and concreted with at least B-20 class concrete or bolted to a concrete base
Boards	HDPE sheets with milled drawings

Due to continuous improvement of technical solutions by Freekids, the presented drawings, including colours and dimensions, may differ slightly from currently manufactured devices.



FreeKids s.c. A. Gąsiorek, Z.Andruszewski
Trzęsowice 32, 55-106 Zawonia

tel./fax: +48 71 312 72 50, +48 724 654 898
e-mail: biuro@freekids.pl www.freekids.pl

rev. 001/2026

Dźwig

0210012

METAL - MINI CITY

DEVICE DATA:

Device dimension	0,85 x 1,83 x 1,48 m
Zone dimension	3,90 x 4,80 m
Fall height	0,30 m
Safety zone area	15,9 m ²
User age	2-6
Number of users	6
Material	Metal
Low fall height	tak
Compliance with standards	PN-EN 1176

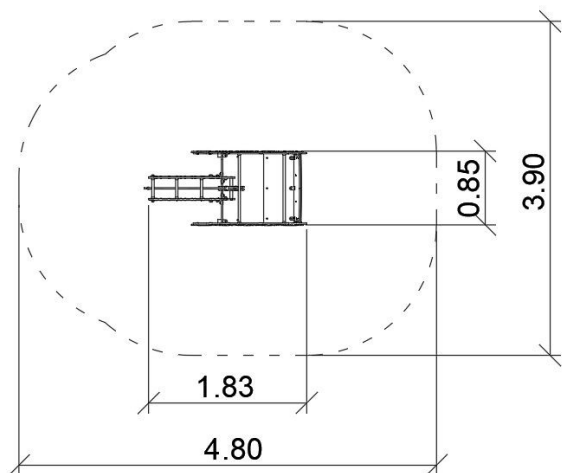

Due to continuous improvement of technical solutions by Freekids, the presented drawings, including colours and dimensions, may differ slightly from currently manufactured devices.