

Horse spring weight swing

0020036

WOOD - SWINGS

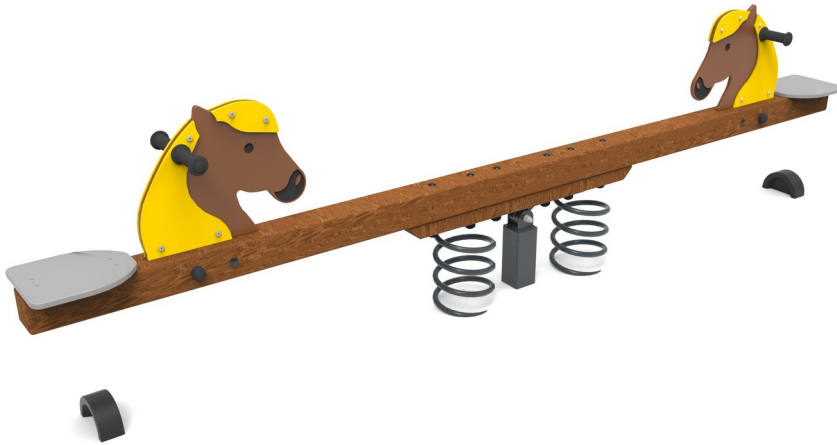

:

--	--

Due to continuous improvement of technical solutions by Freekids, the presented drawings, including colours and dimensions, may differ slightly from currently manufactured devices.



FreeKids s.c. A. Gąsiorek, Z.Andruszewski
Trzęsowice 32, 55-106 Zawonia

tel./fax: +48 71 312 72 50, +48 724 654 898
e-mail: biuro@freekids.pl www.freekids.pl

rev. 001/2025

Horse spring weight swing

0020036

WOOD - SWINGS

DEVICE DATA:

Device dimension	3.00 x 0.35 x 0.74
Zone dimension	6,0 x 3,5
Fall height	0,5 m
Safety zone area	20,1 m ²
User age	3-12
Number of users	2
Material	Wood
Low fall height	yes
Compliance with standards	EN 1176

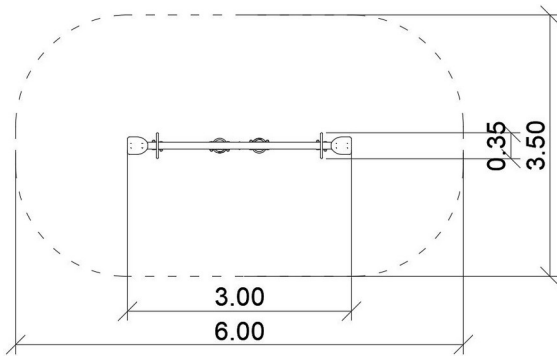

Due to continuous improvement of technical solutions by Freekids, the presented drawings, including colours and dimensions, may differ slightly from currently manufactured devices.



FreeKids s.c. A. Gąsiorek, Z. Andruszewski
Trzęsowice 32, 55-106 Zawonia

tel./fax: +48 71 312 72 50, +48 724 654 898
e-mail: biuro@freekids.pl www.freekids.pl

rev. 001/2025