

# Drabinka A-03

0113011

DREWNO - HOP! Wood



## Material specification:

<b>Construction Material</b>	made of glued wood, surface-impregnated, square cross-section 95 x 95 mm
<b>Additional Elements Handrails</b>	galvanized black steel, powder-coated or stainless steel
<b>Foundation</b>	buried in the ground to a specified depth and concreted with at least B-20 class concrete or bolted to a concrete base
<b>Boards</b>	HDPE sheets with milled drawings

Due to continuous improvement of technical solutions by Freekids, the presented drawings, including colours and dimensions, may differ slightly from currently manufactured devices.



FreeKids s.c. A. Gąsiorek, Z. Andruszewski  
Trzęsowice 32, 55-106 Zawonia

tel./fax: +48 71 312 72 50, +48 724 654 898  
e-mail: [biuro@freekids.pl](mailto:biuro@freekids.pl) [www.freekids.pl](http://www.freekids.pl)

rev. 001/2026

# Drabinka A-03

0113011

**DREWNO - HOP! Wood**

## DEVICE DATA:

Device dimension	1,99 x 0,99 x 1,87 m
Zone dimension	5,40 x 4,20 m
Fall height	1,80 m
Safety zone area	20,4 m <sup>2</sup>
User age	3-12
Number of users	2
Material	Drewno
Low fall height	nie
Compliance with standards	PN-EN 1176

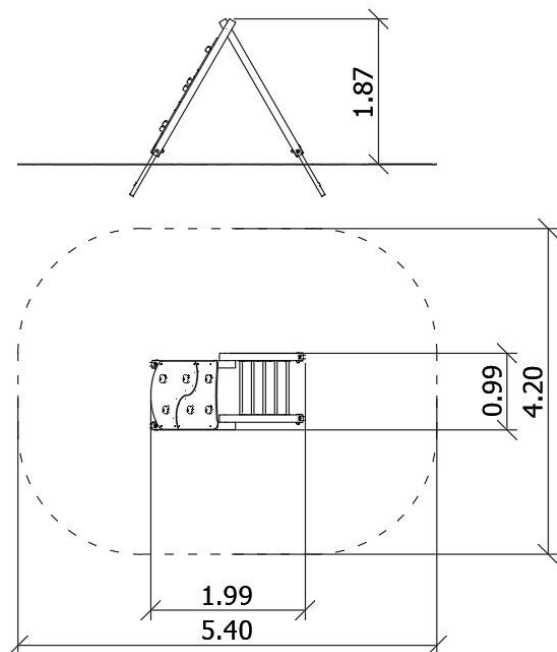

Due to continuous improvement of technical solutions by Freekids, the presented drawings, including colours and dimensions, may differ slightly from currently manufactured devices.



FreeKids s.c. A. Gąsiorek, Z. Andruszewski  
Trzęsowice 32, 55-106 Zawonia

tel./fax: +48 71 312 72 50, +48 724 654 898  
e-mail: [biuro@freekids.pl](mailto:biuro@freekids.pl) [www.freekids.pl](http://www.freekids.pl)

rev. 001/2026