

# Ścianka wspinaczkowa na skarpe

0280117

**METAL - NA SKARPE**

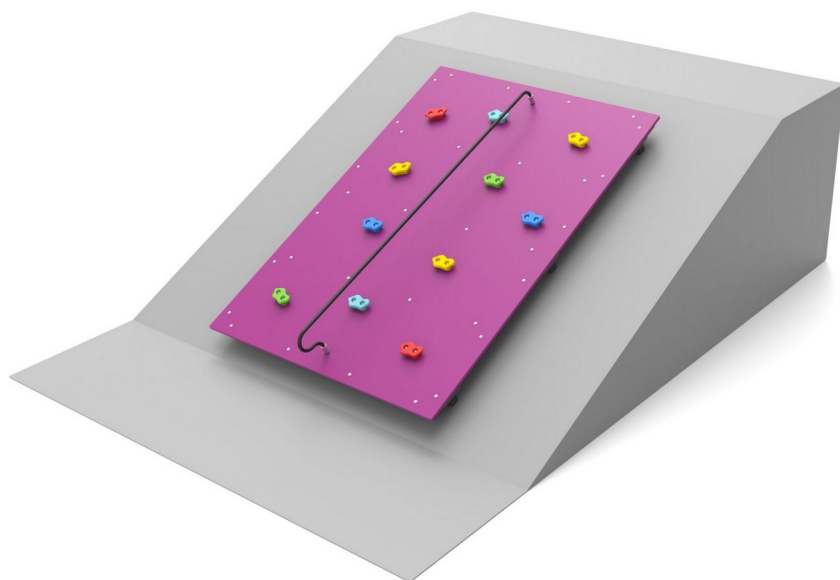

## Material specification:

<b>Construction Material</b>	galvanized steel coated with powder paint for durability and corrosion resistance
<b>Additional Elements Handrails</b>	galvanized black steel, powder-coated
<b>Foundation</b>	buried in the ground to a specified depth and concreted with at least B-20 class concrete or bolted to a concrete base
<b>Sheets</b>	HDPE sheets with milled drawings
<b>Other</b>	Śruby wykonane ze stali nierdzewnej z poliamidowymi nakładkami. Kamienie wspinaczkowe z wytrzymałego tworzywa.

Due to continuous improvement of technical solutions by Freekids, the presented drawings, including colours and dimensions, may differ slightly from currently manufactured devices.



FreeKids s.c. A. Gąsiorek, Z.Andruszewski  
Trzęsowice 32, 55-106 Zawonia

tel./fax: +48 71 312 72 50, +48 724 654 898  
e-mail: [biuro@freekids.pl](mailto:biuro@freekids.pl) [www.freekids.pl](http://www.freekids.pl)

rev. 001/2026

# Ścianka wspinaczkowa na skarpe

0280117

**METAL - NA SKARPE**

## DEVICE DATA:

Device dimension	1,80 x 1,30 m
Zone dimension	4,80 x 4,30 m
Fall height	0,15 m
Safety zone area	18,70 m <sup>2</sup>
User age	3-12
Number of users	3
Material	Metal
Low fall height	tak
Compliance with standards	PN-EN 1176

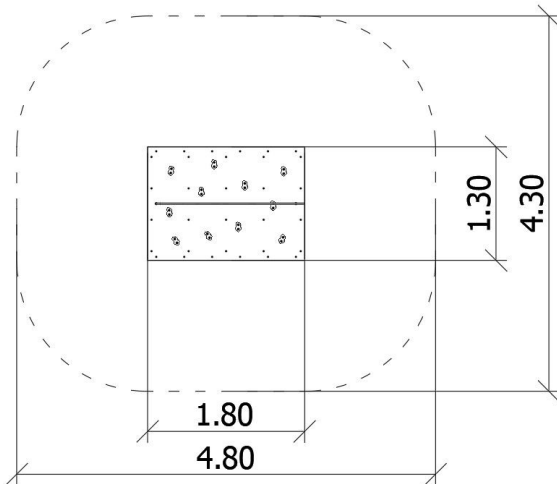

Due to continuous improvement of technical solutions by Freekids, the presented drawings, including colours and dimensions, may differ slightly from currently manufactured devices.



FreeKids s.c. A. Gąsiorek, Z. Andruszewski  
Trzęsowice 32, 55-106 Zawonia

tel./fax: +48 71 312 72 50, +48 724 654 898  
e-mail: [biuro@freekids.pl](mailto:biuro@freekids.pl) [www.freekids.pl](http://www.freekids.pl)

rev. 001/2026