

# Wyciąg górny

0071012

METAL - FITNESS STANDARD



## Material specification:

<b>Construction Material</b>	galvanized steel coated with powder paint for durability and corrosion resistance or made of stainless steel
<b>Foundation</b>	buried in the ground to a specified depth and concreted with at least B-20 class concrete or bolted to a concrete base
<b>Boards</b>	HDPE sheets with milled drawings
<b>Other</b>	Śruby wykonane ze stali nierdzewnej. Podstopnice stalowe, ocynkowane, malowane proszkowo. Stopnice wykonane z blachy aluminiowej ryflowanej. Łożyska toczone kulkowe zwykłe.

Due to continuous improvement of technical solutions by Freekids, the presented drawings, including colours and dimensions, may differ slightly from currently manufactured devices.



FreeKids s.c. A. Gąsiorek, Z.Andruszewski  
Trzęsowice 32, 55-106 Zawonia

tel./fax: +48 71 312 72 50, +48 724 654 898  
e-mail: [biuro@freekids.pl](mailto:biuro@freekids.pl) [www.freekids.pl](http://www.freekids.pl)

rev. 001/2026

# Wyciąg górny

0071012

METAL - FITNESS STANDARD

## DEVICE DATA:

Device dimension	0,79 x 1,18 x 1,93 m
Zone dimension	3,79 x 2,62
Fall height	0,72 m
Safety zone area	8,98 m <sup>2</sup>
User age	14+
Number of users	140 kg
Material	Metal
Low fall height	tak
Compliance with standards	PN-EN 16630

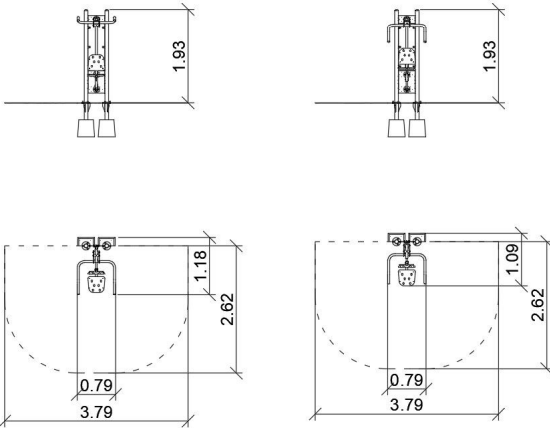

## Wyciąg górny:

### Funkcje urządzenia:

Urządzenie wzmacnia i buduje mięśnie klatki piersiowej, grzbietowe i ramion.

### Sposób ćwiczenia:

Usiądź wygodnie na siedzisku, oprzyj plecy. Złap oburącz uchwyty. Dociśnij je do siebie zdecydowanym, ale płynnym ruchem, zginając ręce w łokciach. Wróć do pozycji wyjściowej. Powtórz ćwiczenie.

Due to continuous improvement of technical solutions by Freekids, the presented drawings, including colours and dimensions, may differ slightly from currently manufactured devices.



FreeKids s.c. A. Gąsiorek, Z.Andruszewski  
Trzęsowice 32, 55-106 Zawonia

tel./fax: +48 71 312 72 50, +48 724 654 898  
e-mail: [biuro@freekids.pl](mailto:biuro@freekids.pl) [www.freekids.pl](http://www.freekids.pl)

rev. 001/2026