

# Triceps Plus

0072019

METAL - FITNESS PLUS



## Material specification:

|                              |  |
|------------------------------|--|
| <b>Construction Material</b> | galvanized steel coated with powder paint for durability and corrosion resistance or made of stainless steel   |
| <b>Foundation</b>            | buried in the ground to a specified depth and concreted with at least B-20 class concrete or bolted to a concrete base   |
| <b>Boards</b>                | Durable HPL sheet  |
| <b>UV Prints</b>             | Multilayer, durable UV prints, resistant to weather conditions   |
| <b>Other</b>                 | Śruby wykonane ze stali nierdzewnej. Podstopnice stalowe, ocynkowane, malowane proszkowo. Stopnice wykonane z blachy aluminiowej ryflowanej. Łożyska toczne kulkowe zwykłe. Wbudowane uchwyty na wodę i telefon. |

Due to continuous improvement of technical solutions by Freekids, the presented drawings, including colours and dimensions, may differ slightly from currently manufactured devices.



FreeKids s.c. A. Gąsiorek, Z.Andruszewski  
Trzęsowice 32, 55-106 Zawonia

tel./fax: +48 71 312 72 50, +48 724 654 898  
e-mail: [biuro@freekids.pl](mailto:biuro@freekids.pl) [www.freekids.pl](http://www.freekids.pl)

rev. 001/2026

# Triceps Plus

0072019

METAL - FITNESS PLUS

## DEVICE DATA:

|                           |                      |
|---------------------------|----------------------|
| Device dimension          | 1,11 x 0,76 x 1,60 m |
| Zone dimension            | 3,76 x 2,60          |
| Fall height               | 0,51 m               |
| Safety zone area          | 8,82 m <sup>2</sup>  |
| User age                  | 14+                  |
| Number of users           | 140 kg               |
| Material                  | Metal                |
| Low fall height           | tak                  |
| Compliance with standards | PN-EN 16630          |

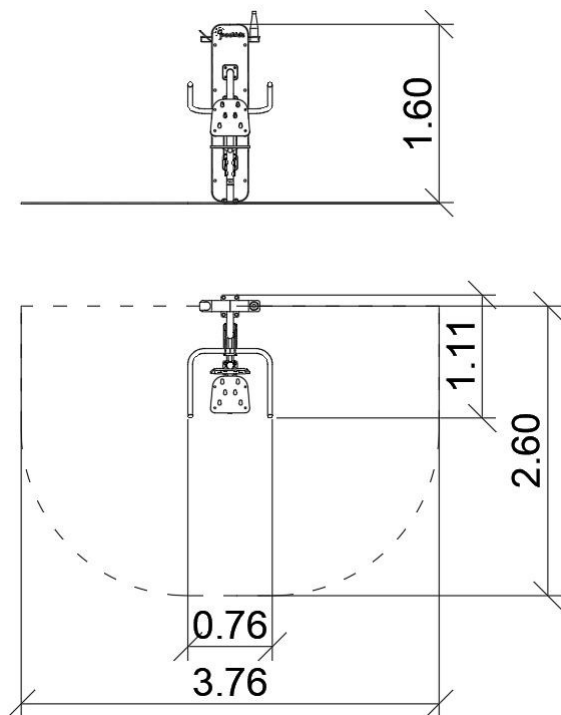

### Triceps:

#### Funkcje urządzenia:

Urządzenie wzmacnia i buduje mięśnie ramion.

#### Sposób ćwiczenia:

Usiądź wygodnie na siedzisku, oprzyj plecy. Złap oburącz uchwyty. Dociśnij je zdecydowanym, ale płynnym ruchem w dół, prostując ręce w łokciach. Wróć do pozycji wyjściowej. Powtórz ćwiczenie.

#### Skład zestawu:

0072000 - Pylon

0071055 - Triceps

Due to continuous improvement of technical solutions by Freekids, the presented drawings, including colours and dimensions, may differ slightly from currently manufactured devices.



FreeKids s.c. A. Gąsiorek, Z. Andruszewski  
Trzęsowice 32, 55-106 Zawonia

tel./fax: +48 71 312 72 50, +48 724 654 898  
e-mail: [biuro@freekids.pl](mailto:biuro@freekids.pl) [www.freekids.pl](http://www.freekids.pl)

rev. 001/2026