



Inclusive

Huśtawka na trójnogu

0020016

METAL - HUŚTAWKI



Material specification:

Construction Material	galvanized steel coated with powder paint for durability and corrosion resistance
Additional Elements Handrails	galvanized black steel, powder-coated
Platforms	HPL Panels
Foundation	buried in the ground to a specified depth and concreted with at least B-20 class concrete
Other	Śruby wykonane ze stali nierdzewnej z poliamidowymi nakładkami. Łańcuchy ze stali nierdzewnej. Bezpieczne i ergonomiczne siedziska.

Due to continuous improvement of technical solutions by Freekids, the presented drawings, including colours and dimensions, may differ slightly from currently manufactured devices.



FreeKids s.c. A. Gąsiorek, Z.Andruszewski
Trzęsowice 32, 55-106 Zawonia

tel./fax: +48 71 312 72 50, +48 724 654 898
e-mail: biuro@freekids.pl www.freekids.pl

rev. 001/2026

Huśtawka na trójnogu

0020016

METAL - HUŚTAWKI

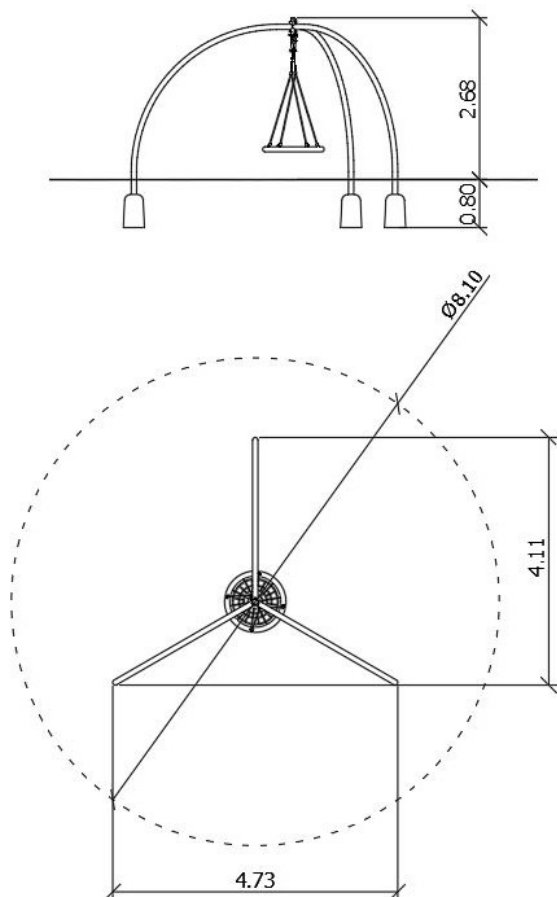

DEVICE DATA:

Device dimension	4,73 x 4,11 x 2,68 m
Zone dimension	Ø 8,10
Fall height	1,40 m
Safety zone area	51,50 m ²
User age	3-12
Number of users	2
Material	Metal
Low fall height	nie
Compliance with standards	PN-EN 1176

Due to continuous improvement of technical solutions by Freekids, the presented drawings, including colours and dimensions, may differ slightly from currently manufactured devices.