

Upper Lift Plus

0072006

METAL - FITNESS PLUS

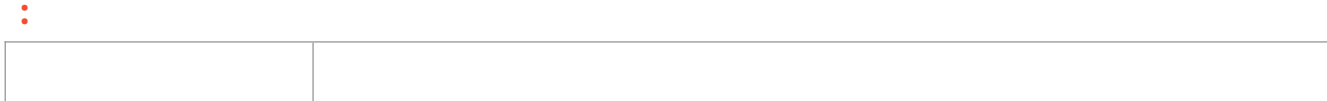
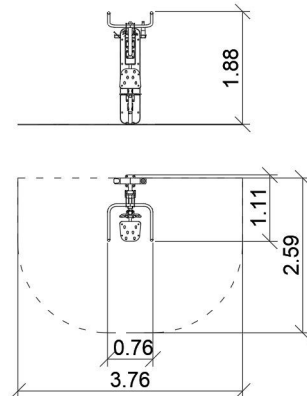

Due to continuous improvement of technical solutions by Freekids, the presented drawings, including colours and dimensions, may differ slightly from currently manufactured devices.



FreeKids s.c. A. Gąsiorek, Z.Andruszewski
Trzęsowice 32, 55-106 Zawonia

tel./fax: +48 71 312 72 50, +48 724 654 898
e-mail: biuro@freekids.pl www.freekids.pl

rev. 001/2026

Upper Lift Plus

0072006

METAL - FITNESS PLUS



DEVICE DATA:

Device dimension	1.11 x 0.76 x 1.88 m
Zone dimension	3.76 x 2.59
Fall height	0,73 m
Safety zone area	8,8 m ²
User age	14+
Number of users	140 kg
Material	Metal
Low fall height	yes
Compliance with standards	PN-EN 16630

Due to continuous improvement of technical solutions by Freekids, the presented drawings, including colours and dimensions, may differ slightly from currently manufactured devices.



FreeKids s.c. A. Gąsiorek, Z. Andruszewski
Trzęsowice 32, 55-106 Zawonia

tel./fax: +48 71 312 72 50, +48 724 654 898
e-mail: biuro@freekids.pl www.freekids.pl

rev. 001/2026